



SQUARE Manual Proximity switch for activation and access control



Hard coated, scratch resistant, anti-reflective, anti-microbial Steritouch acrylic label or Marine grade stainless.
Anti-microbial housings using Steritouch technology
Entire label is sensitive, Weatherproof

www.quantek.co.uk 01246 417113

Remove signage plate by removing two pozi-drive screws. Ascertain fixing height.

Use the box to mark the four fixing points. Use 20mm knockout for cable entry.

Fit seal to back of box if being used externally, and secure box to the wall with 4 x No8 screws.

Make connections (see below, do not leave excessive cable in the back box)

Place signage plate back into the box and insert the two screws.

Do not over tighten screws!

Note: Temporarily tape signage to box to ascertain correct range, adjust accordingly. De-power, remove the yellow adhesive backing and carefully attach the label. Re Power.

Hardwired specification:

12 – 28v dc

Sensitivity - Touch to hands free

Selectable red, green, blue LEDs

Sounder on activation

Timer 1 - 27 seconds

Latching function

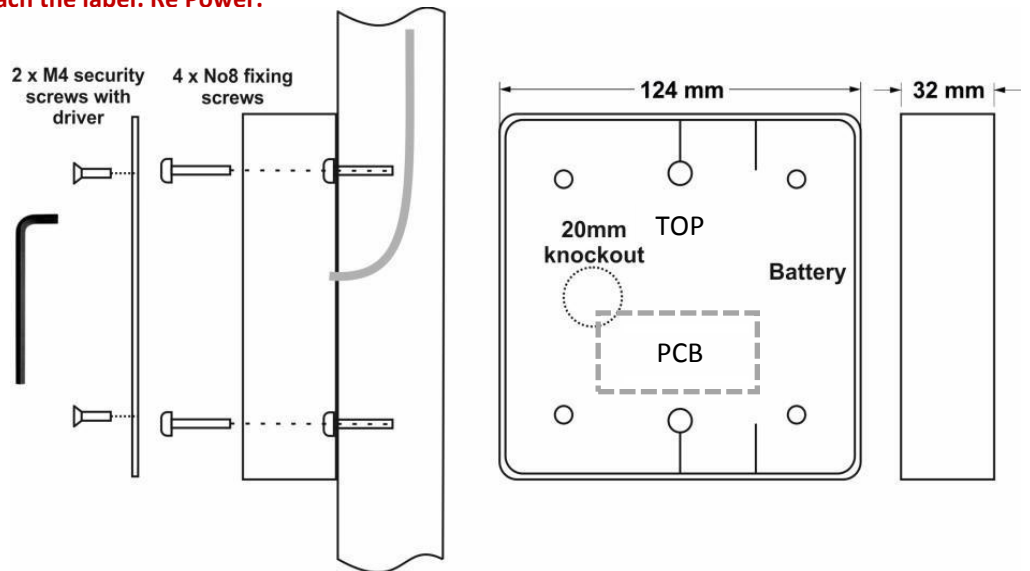

Wiring diagrams

Hardwired sensor wiring. Alter LED colour configuration as required.

Normally open contacts. 0v return

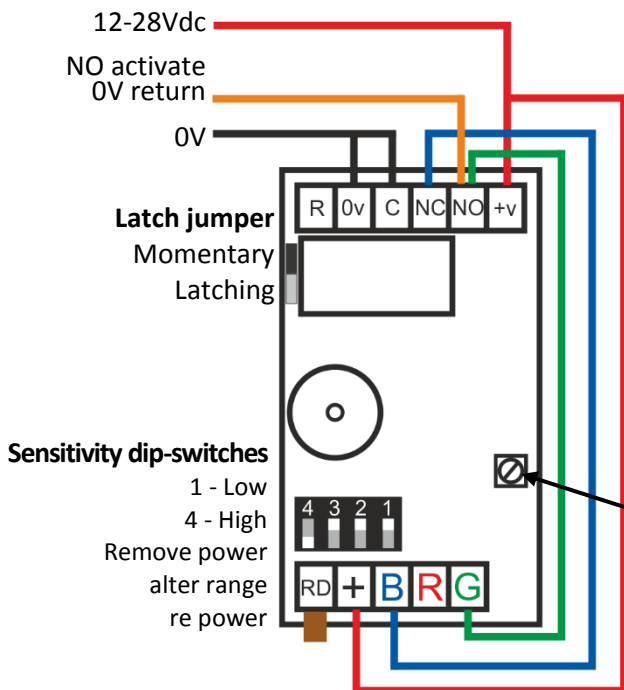

Normally open contacts. +v return

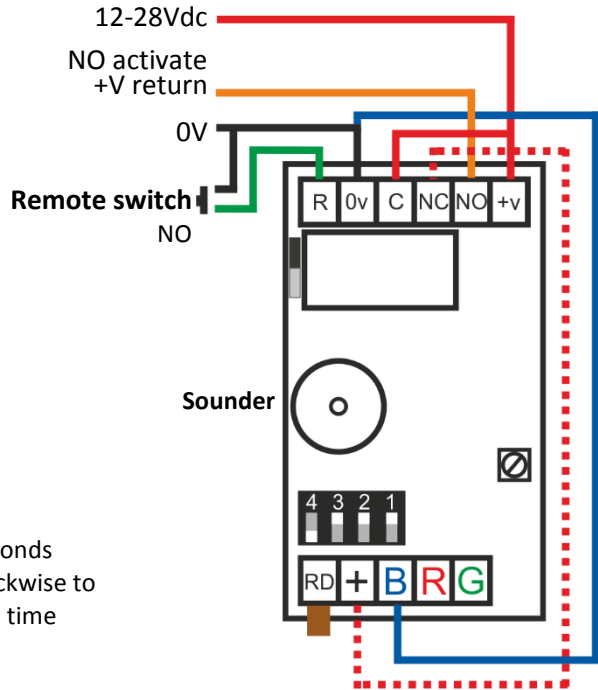

Note: Never connect anything to RD terminal

If using a square illuminated unit, connect LED wires to the terminals marked on the large outer LED panel PCB rather, than the touch sensor PCB.

Radio programming

Supply receiver with 12/24Vdc, power LED will light if powered correctly

Wire relay outputs to activate terminals on the system (clean, normally open contacts)

Press and release the learn button, the learn LED will light up for 10 seconds

Within the 10 seconds operate the touch sensor

The learn LED will flash to confirm it has programmed

Note: Standard touch sensors program to channel 1. The RX-T receiver will be required if you need to program them to different channels.

It is also possible to program our handheld and desk mount transmitters (CFOB, FOB-M, FOB4-M, DDA1, DDA2) into this receiver using the same method. See transmitter box for more details

Reset: To reset the receiver, press and hold the learn button for 10 seconds until the learn LED starts flashing. After this the memory will be deleted

Radio specification

868MHz

4 x AA batteries

Approximately 100,000 operations

Sounder & green LED on activation

Battery saving design, unit will only activate once if hand left on

Receiver specification

12/24Vdc supply

868MHz

2 channels

1A 24Vdc normally open contacts

Momentary/bi-stable selectable relays

200 code memory

Dimensions: 65 x 50 x 30 mm

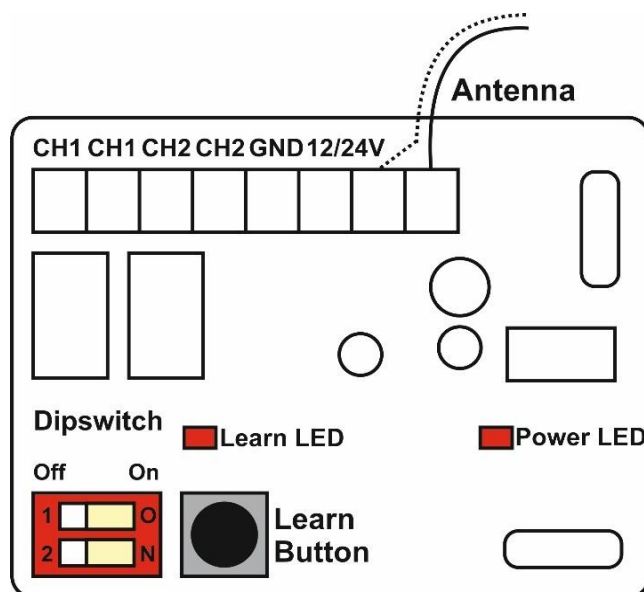

Dipswitch settings		
	ON	OFF
1	CH1 - Bi-Stable	CH1 - Momentary
2	CH2 - Bi-Stable	CH2 - Momentary